

90845 | 90945 | 91245

PLUS

High performance on face milling operations

MILLING

Facing | Slanted Shoulder



PLUS 90845 | 90945

P M K S

INSERT SIZE
05 ON...
0505

ONHX-LP
ONKX-LP

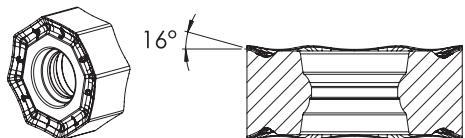

ONHX-MP
ONKX-MP

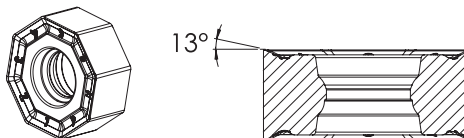

ONHX-MK
ONKX-MK

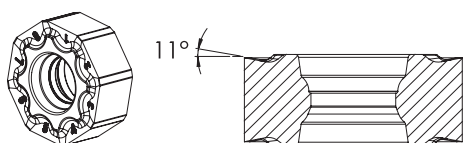

ONHX-W

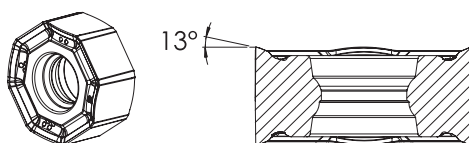

ONHX-LP
ONKX-LP



ONHX-MP
ONKX-MP



ONHX-MK
ONKX-MK



ONHX-W



P M K N S

INSERT SIZE
12 SN...
1206

SNHX-LP

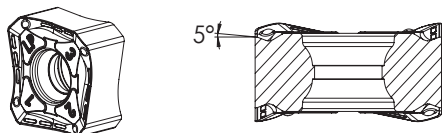

SNHX-MP
SNKX-MP

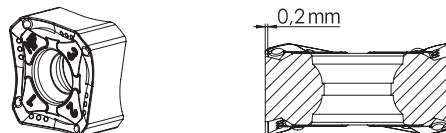

SNHX-MK
SNKX-MK

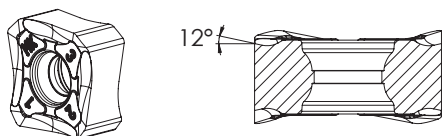

SNHX-LN

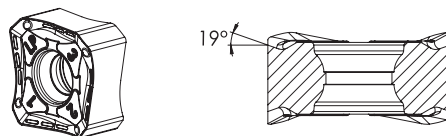

SNHX-W

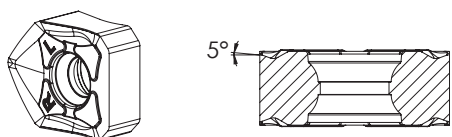

SNHX-LP



SNHX-MP
SNKX-MP



SNHX-MK
SNKX-MK



SNHX-LN



SNHX-W



PLUS 91245

ONHX-LP
ONKX-LP

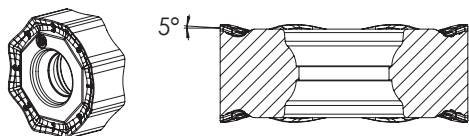

ONHX-MP
ONKX-MP

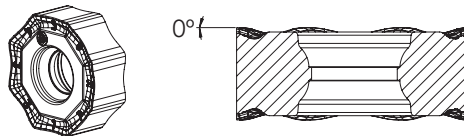

ONHX-LS

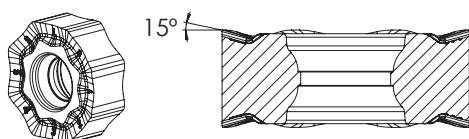

ONHX-W

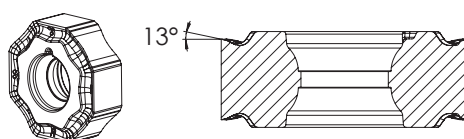

INSERT SIZE
06 ON...
0606

ONHX-LP
ONKX-LP



ONHX-MP
ONKX-MP



ONHX-LS



ONHX-W



SNHX-LP

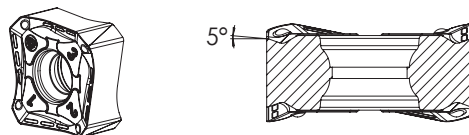

SNHX-MP
SNKX-MP

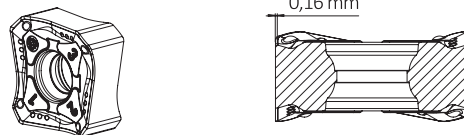

SNHX-MK
SNKX-MK

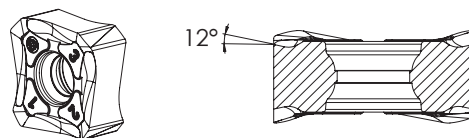

INSERT SIZE
16 SN...
1606

SNHX-LP



SNHX-MP
SNKX-MP



SNHX-MK
SNKX-MK



CHIP BREAKERS Quebra- aparas | Rompevirutas

Chip Breaker	Features Características Características
Geometry LP Light machine	Positive top rake angle to promote a good chip flow and reduce power consumption on low alloy steels.
Geometry MP Light machine	Chip-breaker with a reinforced chamfer for general applications on steel and cast iron.
Geometry MK Light machine	Angles optimized for greater stability and durability of the edge in the machine of cast iron.
Geometry LN Light machine	High positive chip-breaker, polished for applications of non ferrous materials (aluminum).
Geometry LS Light machine	Positive chip-breaker dedicated to stainless steel and HRSA.
Geometry W Light machine	Chip-breaker wiper for the best finishing solutions.

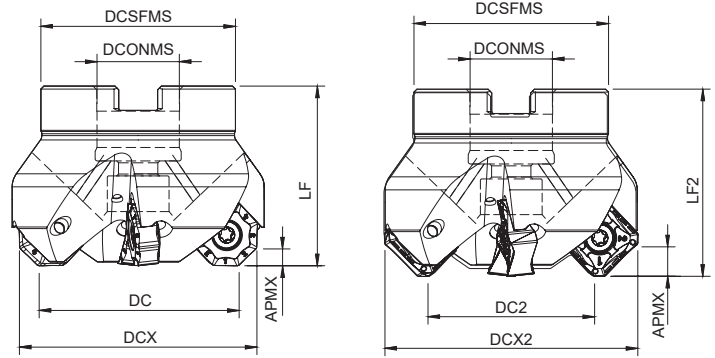

Arbor Mounting

KAPR=44,5°~46° | GAMP=-6°

Order code Código	Reference Referência Referencia	CICT	Dimensions Dimensões Dimensiones (mm)								WT	Specifications		Insert Pastilha Inserto	Stock
			DC	DCX	DC2	DCX2	DCONMS	DCSFMS	LF	LF2		Arbor Type	APMX (mm)		
181111400	050A90845-04-06-022040	4	50	57,6	47,1	62	22	48	40	41,5	0,383	A	3,5 6,0	ON...05 SN...12	☺
181117400	050A90845-06-06-022040	6	50	57,6	47,1	62	22	48	40	41,5	0,374	A	3,5 6,0	ON...05 SN...12	☺
181117500	063A90845-06-06-022040	6	63	70,6	60,1	75	22	52	40	41,5	0,525	A	3,5 6,0	ON...05 SN...12	☺
181117600	063A90845-08-06-022040	8	63	70,6	60,1	75	22	52	40	41,5	0,517	A	3,5 6,0	ON...05 SN...12	☺
181117700	080A90845-07-06-027050	7	80	87,6	77,1	92	27	60	50	51,5	0,846	B	3,5 6,0	ON...05 SN...12	☺
181117800	080A90845-10-06-027050	10	80	87,6	77,1	92	27	60	50	51,5	0,842	B	3,5 6,0	ON...05 SN...12	☺
181117900	100A90845-08-06-032050	8	100	107,6	97,1	112	32	80	50	51,5	1,559	B	3,5 6,0	ON...05 SN...12	☺
181120900	100A90845-12-06-032050	12	100	107,6	97,1	112	32	80	50	51,5	1,54	B	3,5 6,0	ON...05 SN...12	☺
181121000	125A90845-10-06-040063	10	125	132,6	122,1	137	40	90	63	64,5	2,89	B	3,5 6,0	ON...05 SN...12	☺
181121100	160A90845-12-06-U040063	12	160	167,6	157,1	172	40	110	63	64,5	4,36	C	3,5 6,0	ON...05 SN...12	☺
181121200	200A90845-14-06-U060063	14	200	207,6	197,1	212	60	172	63	64,5	8,89	C	3,5 6,0	ON...05 SN...12	☺
181121300	250A90845-16-06-U060063	16	250	257,6	247,1	262	60	172	63	64,5	11,49	C	3,5 6,0	ON...05 SN...12	☺

☺ Stock item | Produto de stock | Itens de stock

○ Available under request (see page A-8) | Disponível sobre consulta (consulte a página A-8) | Disponible bajo consulta (mire pagina A-8)

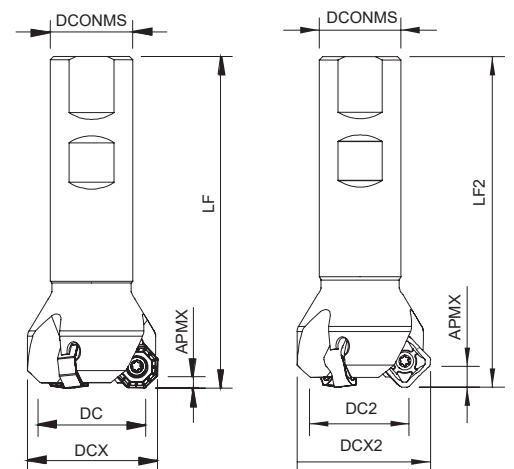

Weldon Shank

KAPR=44,5°~46° | GAMP=-6°

Order code Código	Reference Referência Referencia	CICT	Dimensions Dimensões Dimensiones (mm)							WT	Specifications	Insert Pastilha Inserto	Stock
			DC	DCX	DC2	DCX2	DCONMS	LF	LF2		APMX (mm)		
181118000	032W90845-03-06-025100	3	32	39,6	29,1	44	25	100	101,5	0,375	3,5 6,0	ON...05 SN...12	☺
181118100	040W90845-04-06-032110	4	40	47,6	37,1	52	32	110	111,5	0,653	3,5 6,0	ON...05 SN...12	☺

☺ Stock item | Produto de stock | Itens de stock

○ Available under request (see page A-8) | Disponível sobre consulta (consulte a página A-8) | Disponible bajo consulta (mire pagina A-8)

PLUS 90845

ONHX 05 | ONKX 05 | SNHX 12 | SNKX 12

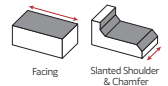

ONH(K)X 05 | SNH(K)X 12 Inserts | Pastilhas | Plaquetas

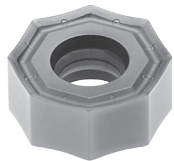

ONH(K)X-LP



ONH(K)X-MP



ONH(K)X-MK

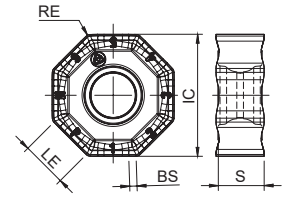

ONH(K)X-LP | MP | MK



ONHX-W
8 Cutting Edges (8R)

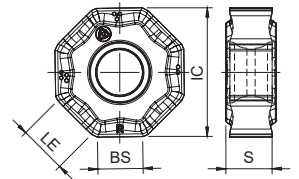

ONHX-W

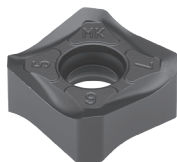

SNH(K)X-MK

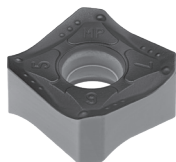

SNH(K)X-MP

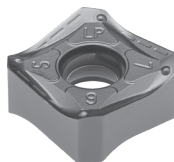

SNHX-LP

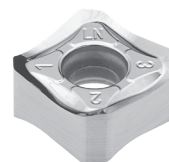

SNHX-LN

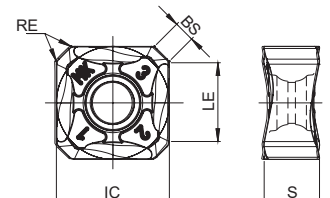

SNH(K)X-MK | MP | LP | LN

Geometry code	ISO Reference	P																		M		K						N	S		Dimensions Dimensões Dimensiones (mm)				
		CVD		PVD						PVD		CVD			PVD			UNC	PVD		IC	S	LE	RE	BS										
		T9	X5	G4	T1	P3	P4	G6	X9	G6	L5	L6	L9	T9	X5	G4	T1	P3	P4	G6						10	X9	G6							
1112302	ONHX 050505 ANEN-LP				⊗		⊗	⊗		⊗								⊗	⊗	⊗		⊗		12,70	5,20	5,30	0,50	-							
1112304	ONHX 050505 ANSN-MP				⊗		⊗											⊗	⊗					12,70	5,20	5,30	0,50	-							
1112301	ONKX 050505 ANEN-LP	○		⊗	⊗	⊗		○	⊗				○		⊗	⊗	⊗	⊗	⊗	○		⊗	○	12,70	5,20	5,30	0,50	-							
1112303	ONKX 050505 ANSN-MP	⊗		⊗	⊗	⊗							⊗		⊗	⊗	⊗	⊗	⊗					12,70	5,20	5,30	0,50	-							
1112305	ONKX 050500 ANEN-MK											○	⊗	⊗				⊗						12,70	5,20	5,30	-	-							
1112307	ONHX 050500 ANER-W			⊗	⊗							⊗						⊗	⊗					12,70	5,20	5,30	-	4,30							
1111452	SNHX 1206 ANEN-LP				⊗		⊗		⊗									⊗	⊗	○		⊗	○	12,70	6,35	9,30	0,80	2,00							
1111502	SNHX 1206 ANSN-MP	⊗	⊗	⊗	⊗		⊗							⊗	⊗		⊗	⊗	○		○	○	12,70	6,35	9,30	0,80	2,00								
1111503	SNHX 1206 ANEN-MK											⊗		⊗	⊗	⊗	⊗							12,70	6,35	9,30	0,80	2,00							
1111504	SNHX 1206 ANFN-LN																					⊗		12,70	6,35	9,30	0,80	2,00							
1112293	SNKX 1206 ANSN-MP	⊗		⊗	⊗		⊗					○	⊗		⊗	⊗		⊗			⊗		⊗	12,70	6,35	9,30	0,80	2,00							
1112249	SNKX 1206 ANEN-MK											⊗	⊗	⊗										12,70	6,35	9,30	0,80	2,00							

⊗ First choice | 1ª Escolha | 1ª Opción ⊗ Stock available until sold out | Stock disponível até acabar o stock | Stock disponible hasta acabar el stock
 ⊗ Stock Items | Itens de stock ○ Available under request (see page A-9) | Disponível sobre consulta (consulte a página A-9) | Disponible bajo consulta (mire pagina A-9)

Insert Order Code: (1) Geometry code + (2) Grade code



SPARE PARTS Accessórios | Repuestos

Cutter DC	Insert Screw	Key (Torx)	Order separately		Order separately	
			Key (Torx - Nm)	Torque Value	Screw	DIN 6368 Wrench
A90845 - 50 - 63	P0401200	XT15	DT1530	3,00	-	-
A90845 - 80	P0401200	XT15	DT1530	3,0	J0123510	SD6368-12
A90845 - 100	P0401200	PT15	DT1530	3,0	J0164110	SD6368-16
A90845 - 125	P0401200	PT15	DT1530	3,0	J0204610	SD6368-20
A90845 - 160 - 250	P0401200	PT15	DT1530	3,0	-	-
W90845 - 32 - 40	P0401200	XT15	DT1530	3,0	-	-

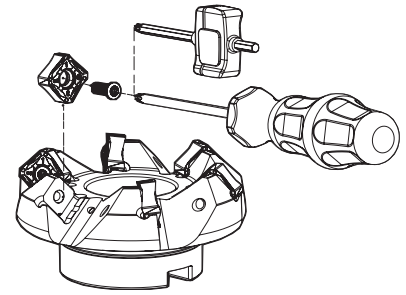

Note: The toolholder is supplied with the XT/PT key. To order the DT key please check the page A-301.
Check the procedures for the clamping screws on the page A-301.

GRADES SELECTION GUIDE Guia para selecção de graus | Tabla para selección de calidades

ISO	PSM	Material	HB (Brinell)	Grades										
				← Wear Resistance						Toughness →				
				PH0910	PH5705	PH5320	PHP910	PHP920	PH7920	PHP930	PHH930	PH7930	PH5740	PHS740
P	1	Unalloyed Steel	125-220				✓	✓	✓	✓		✓	✓	✓
	2	Low-Alloyed Steel	220-280				✓	✓	✓	✓		✓	✓	✓
	3	High-Alloyed Steel	280-380				✓	✓	✓	✓		✓	✓	✓
M	4	SS - Ferritic / Martensitic	200-330								✓	✓		✓
	5	SS - Austenitic	200-330								✓	✓		✓
	6	SS - Austenitic-ferritic (Duplex)	230-260								✓	✓		✓
K	7	Malleable Cast Iron	130-230		✓	✓	✓	✓	✓	✓		✓	✓	✓
	8	Grey Cast Iron	180-245		✓	✓	✓	✓	✓	✓		✓	✓	✓
	9	Nodular Cast iron	160-250		✓	✓	✓	✓	✓	✓		✓	✓	✓
N	10	Aluminium and Non Ferrous	30-130	✓										
S	11	Heat Resistant Super Alloys	200-320									✓	✓	✓

Good Conditions
 Average Conditions
 Difficult Conditions

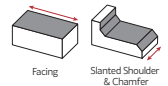

RECOMMENDED CUTTING CONDITIONS Condições de corte recomendadas | Condiciones de corte recomendables

ISO	PSM	Material	HB (Brinell)	Vc (m/min)						
				← Wear Resistance					Toughness →	
				PH0910	PH5705	PH5320	PHP910	PHP920	PH7920	PHP930
P	1	Unalloyed Steel	125-220	-	-	-	180-250	180-250	180-240	160-220
	2	Low-Alloyed Steel	220-280	-	-	-	160-240	160-230	160-220	140-200
	3	High-Alloyed Steel	280-380	-	-	-	140-230	140-220	140-210	120-190
M	4	SS - Ferritic / Martensitic	200-330	-	-	-	-	-	140-220	140-200
	5	SS - Austenitic	200-330	-	-	-	-	-	130-180	120-160
	6	SS - Austenitic-ferritic (Duplex)	230-260	-	-	-	-	-	120-160	100-140
K	7	Malleable Cast Iron	130-230	-	160-290	150-280	180-300	160-270	160-260	150-240
	8	Grey Cast Iron	180-245	-	170-320	160-320	160-250	140-250	140-240	140-230
	9	Nodular Cast iron	160-250	-	140-200	100-190	150-210	120-210	120-200	100-190
N	10	Aluminium and Non Ferrous	30-130	100-2000	-	-	-	-	-	-
S	11	Heat Resistant Super Alloys	200-320	-	-	-	-	-	-	30-100

ISO	PSM	Material	HB (Brinell)	Vc (m/min)					Feed fz (mm/t)	
				← Wear Resistance			Toughness →			
				PHH930	PH7930	PH5740	PHS740	PH7740	SNH(K)X 12...	ONH(K)X 05...
P	1	Unalloyed Steel	125-220	-	160-220	-	140-220	140-200	0,10-0,35	0,10-0,35
	2	Low-Alloyed Steel	220-280	-	140-200	-	120-200	130-180	0,10-0,35	0,10-0,35
	3	High-Alloyed Steel	280-380	-	120-190	-	100-190	100-170	0,10-0,30	0,10-0,30
M	4	SS - Ferritic / Martensitic	200-330	140-210	140-200	-	-	130-180	0,10-0,30	0,10-0,30
	5	SS - Austenitic	200-330	120-170	120-160	-	-	110-160	0,10-0,30	0,10-0,30
	6	SS - Austenitic-ferritic (Duplex)	230-260	100-150	100-140	-	-	90-150	0,10-0,25	0,10-0,25
K	7	Malleable Cast Iron	130-230	-	150-240	160-260	-	140-220	0,10-0,35	0,10-0,35
	8	Grey Cast Iron	180-245	-	140-230	140-240	-	120-210	0,10-0,35	0,10-0,35
	9	Nodular Cast iron	160-250	-	100-190	120-200	-	100-190	0,10-0,30	0,10-0,30
N	10	Aluminium and Non Ferrous	30-130	-	-	-	-	-	0,10-0,35	-
S	11	Heat Resistant Super Alloys	200-320	30-110	30-100	-	-	30-100	0,07-0,20	0,07-0,18

(Note 1) Cutting conditions $a_e/D_c=70\%$.

(Note 2) It's possible to occur vibrations in certain cases. Please reduce depth of cut and / or reduce cutting conditions in following cases:

- When using long shank;
- When using long tool overhang with arbor type;
- When application has poor clamping rigidity or when using a low rigidity machine.

CHIP BREAKER SELECTION GUIDE Guia para aplicações do quebra- aparas | Guía para aplicación del rompevirutas

ISO	PSM	Material	HB (Brinell)	Chip breaker application	
				1st choice	Difficult Operations
				P	1
2	Low-Alloyed Steel	220-280	LP		MP
3	High-Alloyed Steel	280-380	MP		-
M	4	SS - Ferritic / Martensitic	200-330	LP	MP
	5	SS - Austenitic	200-330	LP	-
	6	SS - Austenitic-ferritic (Duplex)	230-260	LP	-
K	7	Malleable Cast Iron	130-230	MK	-
	8	Grey Cast Iron	180-245	MK	-
	9	Nodular Cast iron	160-250	MK	-
N	10	Aluminium and Non Ferrous	30-130	LN	-
S	11	Heat Resistant Super Alloys	200-320	LP	-

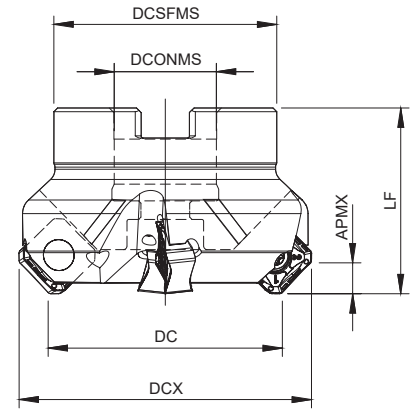

Arbor Mounting

KAPR=44,5°~46° | GAMP=-6°

Order code Código	Reference Referência Referencia	CICT	Dimensions Dimensões Dimensiones (mm)					WT	Specifications		Insert Pastilha Inserto	Stock
			DC	DCX	DCONMS	DCSFMS	LF		Arbor Type	APMX (mm)		
181111400	050A90845-04-06-022040	4	50	57,6	22	48	40	0,383	A	3,5 6,0	ON...05 SN...12	☺
181117400	050A90845-06-06-022040	6	50	57,6	22	48	40	0,374	A	3,5 6,0	ON...05 SN...12	☺
181117500	063A90845-06-06-022040	6	63	70,6	22	52	40	0,525	A	3,5 6,0	ON...05 SN...12	☺
181117600	063A90845-08-06-022040	8	63	70,6	22	52	40	0,517	A	3,5 6,0	ON...05 SN...12	☺
181117700	080A90845-07-06-027050	7	80	87,6	27	60	50	0,846	B	3,5 6,0	ON...05 SN...12	☺
181117800	080A90845-10-06-027050	10	80	87,6	27	60	50	0,842	B	3,5 6,0	ON...05 SN...12	☺
181117900	100A90845-08-06-032050	8	100	107,6	32	80	50	1,559	B	3,5 6,0	ON...05 SN...12	☺
181120900	100A90845-12-06-032050	12	100	107,6	32	80	50	1,54	B	3,5 6,0	ON...05 SN...12	☺
181121000	125A90845-10-06-040063	10	125	132,6	40	90	63	2,89	B	3,5 6,0	ON...05 SN...12	☺
181121100	160A90845-12-06-U040063	12	160	167,6	40	110	63	4,36	C	3,5 6,0	ON...05 SN...12	☺
181121200	200A90845-14-06-U060063	14	200	207,6	60	172	63	8,89	C	3,5 6,0	ON...05 SN...12	☺
181121300	250A90845-16-06-U060063	16	250	257,6	60	172	63	11,49	C	3,5 6,0	ON...05 SN...12	☺

☺ Stock item | Produto de stock | Itens de stock

○ Available under request (see page A-8) | Disponível sobre consulta (consulte a página A-8) | Disponible bajo consulta (mire pagina A-8)

SPARE PARTS Acessórios | Repuestos

Cutter DC	Insert Screw	Key (Torx)	Order separately		Order separately	
			Key (Torx - Nm)	Torque Value	Screw	DIN 6368 Wrench
A90945 - 50 - 63	P0401200	XT15	DT1530	3,00	-	-
A90945 - 80	P0401200	XT15	DT1530	3,0	J0123510	SD6368-12
A90945 - 100	P0401200	PT15	DT1530	3,0	J0164110	SD6368-16
A90945 - 125	P0401200	PT15	DT1530	3,0	J0204610	SD6368-20
A90945 - 160 - 250	P0401200	PT15	DT1530	3,0	-	-

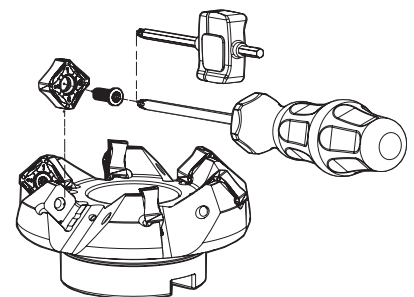

Note: The toolholder is supplied with the XT/PT key. To order the DT key please check the page A-301.
Check the procedures for the clamping screws on the page A-301.

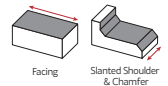

SNH(K)X 12 Inserts | Pastilhas | Plaquetas

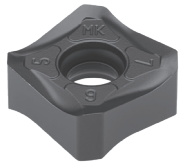

SNH(K)X-MK

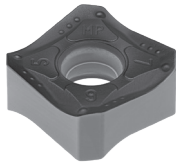

SNH(K)X-MP

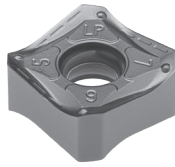

SNHX-LP

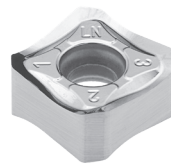

SNHX-LN

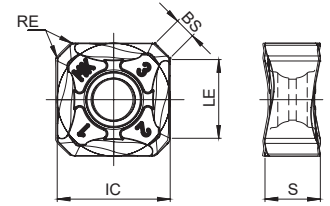

SNH(K)X- MK | LP | MP | LN



SNHX-W
4 Cutting edges (2R + 2L)

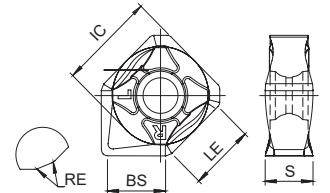

SNHX-W

(1) Geometry code	ISO Reference	P							M		K						N	S	Dimensions Dimensões Dimensiones (mm)										
		CVD		PVD					PVD		CVD			PVD			UNC	PVD											
		T9	X5	G4	T1	P3	P4	G6	X9	G6	L5	L6	L9	T9	X5	G4	T1	P3						P4	G6	10	X9	G6	
1112293	SNKX 1206 ANSN-MP	⊗		⊗	⊗			⊗					⊗	⊗		⊗	⊗			⊗				⊗	12,70	6,35	9,30	0,80	2,00
1112249	SNKX 1206 ANEN-MK										⊗	⊗	⊗												12,70	6,35	9,30	0,80	2,00
1111452	SNHX 1206 ANEN-LP				⊗		⊗		⊗							⊗	⊗			⊗		⊗	⊗	12,70	6,35	9,30	0,80	2,00	
1111502	SNHX 1206 ANSN-MP	⊗	⊗	⊗	⊗		⊗						⊗	⊗		⊗	⊗			⊗		⊗	⊗	12,70	6,35	9,30	0,80	2,00	
1111503	SNHX 1206 ANEN-MK										⊗		⊗	⊗	⊗									12,70	6,35	9,30	0,80	2,00	
1111504	SNHX 1206 ANFN-LN																			⊗				12,70	6,35	9,30	0,80	2,00	
1111899	SNHX 1206 ANFN-W*		⊗		⊗											⊗	⊗							12,70	6,30	9,30	0,40	7,60	

⊗ First choice | 1ª Escolha | 1ª Opción ⊗ Stock available until sold out | Stock disponível até acabar o stock | Stock disponible hasta acabar el stock
 ⊗ Stock items | Itens de stock ○ Available under request (see page A-9) | Disponível sobre consulta (consulte a página A-9) | Disponible bajo consulta (mire pagina A-9)

* Wiper insert with 2 rights and 2 left-hand cutting edges.

RECOMMENDED CUTTING CONDITIONS Condições de corte recomendadas | Condiciones de corte recomendables

ISO	PSM	Material	HB (Brinell)	Vc (m/min)									
				← Wear Resistance								Toughness →	
				PH0910	PH5705	PH5320	PHP910	PHP920	PH7920	PHP930	PHH930	PH7930	PH5740
P	1	Unalloyed Steel	125-220	-	-	-	180-250	180-250	180-240	160-220	-	160-220	-
	2	Low-Alloyed Steel	220-280	-	-	-	160-240	160-230	160-220	140-200	-	140-200	-
	3	High-Alloyed Steel	280-380	-	-	-	140-230	140-220	140-210	120-190	-	120-190	-
M	4	SS - Ferritic / Martensitic	200-330	-	-	-	-	-	140-220	140-200	140-210	140-200	-
	5	SS - Austenitic	200-330	-	-	-	-	-	130-180	120-160	120-170	120-160	-
	6	SS - Austenitic-ferritic (Duplex)	230-260	-	-	-	-	-	120-160	100-140	100-150	100-140	-
K	7	Malleable Cast Iron	130-230	-	160-290	150-280	180-300	160-270	160-260	150-240	-	150-240	160-260
	8	Grey Cast Iron	180-245	-	170-320	160-320	160-250	140-250	140-240	140-230	-	140-230	140-240
	9	Nodular Cast iron	160-250	-	140-200	100-190	150-210	120-210	120-200	100-190	-	100-190	120-200
N	10	Aluminium and Non Ferrous	30-130	100-2000	-	-	-	-	-	-	-	-	-
S	11	Heat Resistant Super Alloys	200-320	-	-	-	-	-	-	30-100	30-110	30-100	-

ISO	PSM	Material	HB (Brinell)	Vc (m/min)		Feed fz (mm/t)					
				Toughness →							
				PH5740	PH7740	SNHX 12... LP	SNH(K)X 12... MP	SNH(K)X 12... MK	SNHX 12... LN	SNHX 12... W	
P	1	Unalloyed Steel	125-220	140-220	140-200	0,10-0,35	0,10-0,35	-	-	-	0,10-0,35
	2	Low-Alloyed Steel	220-280	120-200	130-180	0,10-0,35	0,10-0,35	-	-	-	0,10-0,35
	3	High-Alloyed Steel	280-380	100-190	100-170	0,10-0,30	0,10-0,30	-	-	-	0,10-0,30
M	4	SS - Ferritic / Martensitic	200-330	-	130-180	0,10-0,30	-	-	-	-	-
	5	SS - Austenitic	200-330	-	110-160	0,10-0,30	-	-	-	-	-
	6	SS - Austenitic-ferritic (Duplex)	230-260	-	90-150	0,10-0,25	-	-	-	-	-
K	7	Malleable Cast Iron	130-230	-	140-220	0,10-0,35	-	0,10-0,35	-	-	0,10-0,40
	8	Grey Cast Iron	180-245	-	120-210	0,10-0,35	-	0,10-0,35	-	-	0,10-0,40
	9	Nodular Cast iron	160-250	-	100-190	0,10-0,30	-	0,10-0,30	-	-	0,10-0,40
N	10	Aluminium and Non Ferrous	30-130	-	-	-	-	-	0,10-0,35	-	-
S	11	Heat Resistant Super Alloys	200-320	-	30-100	0,07-0,20	-	-	-	-	-

(Note 1) Cutting conditions $a_e/D_c=70\%$.

(Note 2) It's possible to occur vibrations in certain cases. Please reduce depth of cut and / or reduce cutting conditions in following cases:

- When using long shank;
- When using long tool overhang with arbor type;
- When application has poor clamping rigidity or when using a low rigidity machine.

GRADES SELECTION GUIDE Guia para selecção de graus | Tabla para selección de calidades

ISO	PSM	Material	HB (Brinell)	Grades										
				← Wear Resistance								Toughness →		
				PH0910	PH5705	PH5320	PHP910	PHP920	PH7920	PHP930	PHH930	PH7930	PH5740	PH7740
P	1	Unalloyed Steel	125-220	●	●	●	●	●	●	●	●	●	●	●
	2	Low-Alloyed Steel	220-280				●	●	●	●		●		●
	3	High-Alloyed Steel	280-380				●	●	●	●		●		●
M	4	SS - Ferritic / Martensitic	200-330								●	●		●
	5	SS - Austenitic	200-330								●	●		●
	6	SS - Austenitic-ferritic (Duplex)	230-260								●	●		●
K	7	Malleable Cast Iron	130-230		●	●	●	●	●	●		●	●	●
	8	Grey Cast Iron	180-245		●	●	●	●	●	●		●	●	●
	9	Nodular Cast iron	160-250		●	●	●	●	●	●		●	●	●
N	10	Aluminium and Non Ferrous	30-130	●										
S	11	Heat Resistant Super Alloys	200-320								●	●		●

● Good Conditions

● Average Conditions

● Difficult Conditions

CHIP BREAKER SELECTION GUIDE Guia para aplicações do quebra- aparas | Guía para aplicación del rompevirutas

ISO	PSM	Material	HB (Brinell)	Chip breaker application	
				1st choice	Difficult Operations
P	1	Unalloyed Steel	125-220	SNHX 12... LP	SNH(K)X 12... MP
	2	Low-Alloyed Steel	220-280	SNHX 12... LP	SNH(K)X 12... MP
	3	High-Alloyed Steel	280-380	SNH(K)X 12... MP	-
M	4	SS - Ferritic / Martensitic	200-330	SNHX 12... LP	-
	5	SS - Austenitic	200-330	SNHX 12... LP	-
	6	SS - Austenitic-ferritic (Duplex)	230-260	SNHX 12... LP	-
K	7	Malleable Cast Iron	130-230	SNH(K)X 12... MK	-
	8	Grey Cast Iron	180-245	SNH(K)X 12... MK	-
	9	Nodular Cast iron	160-250	SNH(K)X 12... MK	-
N	10	Aluminium and Non Ferrous	30-130	SNHX 12... LN	-
S	11	Heat Resistant Super Alloys	200-320	SNHX 12... LP	-

WIPER INSERTS

Recommended Cutting Conditions:

- f_n should be equal to $0,8 \times BS_W$
- Axial depth of cut is 0,5 to 0,8mm.

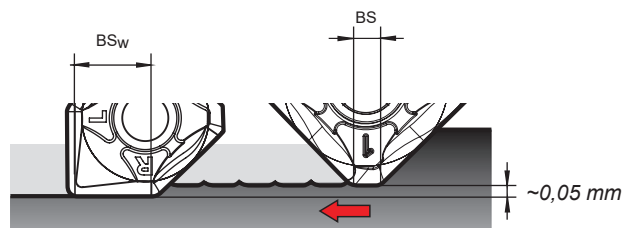

Example:

- The width of the parallel land (BS) of the insert is 2mm.
- To obtain a good surface finishing, the feed per revolution should be a maximum of 80% of 2mm = 1,6mm.
- The wiper insert will have a parallel land (BS_W) with a width of 7,6mm.
- Result: Feed per revolution (f_n) could be increased from 1,6mm to 6,1mm (80% of 7,6mm).

Note:

- Other limitations, such as machine power, must be taken into consideration.
- $f_n \leq 0,8 \times BS_W = f_z \leq 0,8 \times BS_W / Z$

How to use a wiper insert:

- Since wiper is one corner use to standard cutters, please attach the insert with the parallel land down to the workpiece cutting surface.

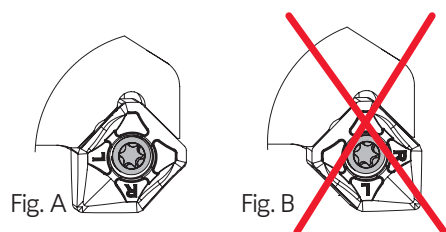

When using wiper insert, install the insert as shown on Fig. A if the insert is installed as shown on Fig. B breakage of the insert is inevitable and normal surface finish can not be obtained.

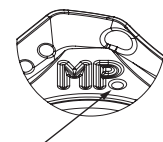
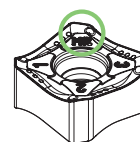

This point shows the SNKX insert difference to SNHX

Put the same side of insert in each pocket for best radial and axial runout when using SNKX.

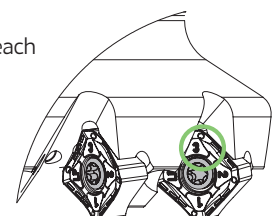

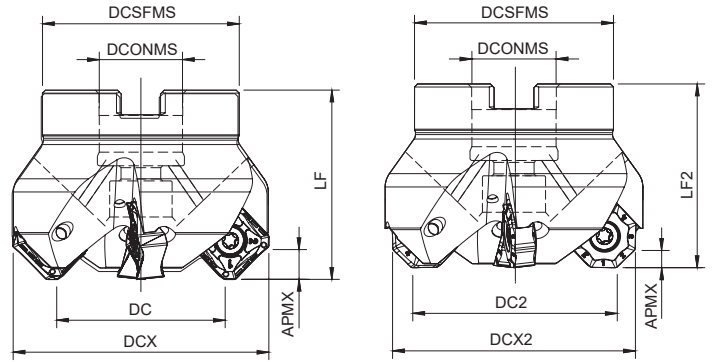
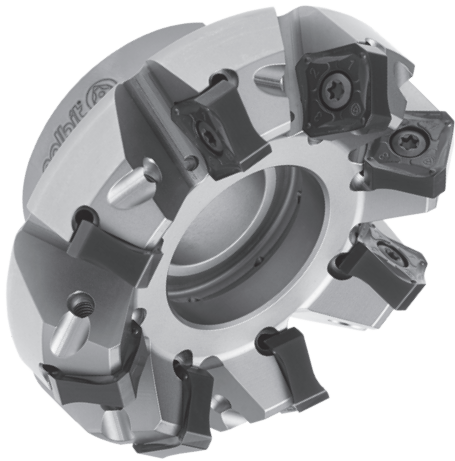

Arbor Mounting

KAPR=44,5°~46° | GAMP=-6°

Order code Código	Reference Referência Referencia	CICT	Dimensions Dimensões Dimensiones (mm)								WT	Specifications		Insert Pastilha Inserto	Stock
			DC	DCX	DC2	DCX2	DCONMS	DCSFMS	LF	LF2		Arbor Type	APMX (mm)		
181088900	063A91245-05-06-022050	5	63	80,1	66,6	76,0	22	52	50	48	0,81	A	3,8 8,5	ON...06 SN...16	📦
181089000	080A91245-06-06-027050	6	80	97,1	83,6	93,0	27	60	50	48	1,06	B	3,8 8,5	ON...06 SN...16	📦
181089100	080A91245-08-06-027050	8	80	97,1	83,6	93,0	27	60	50	48	1,09	B	3,8 8,5	ON...06 SN...16	📦
181089200	100A91245-07-06-032063	7	100	117,1	103,6	113,0	32	80	63	61	2,24	B	3,8 8,5	ON...06 SN...16	📦
181089300	100A91245-10-06-032063	10	100	117,1	103,6	113,0	32	80	63	61	2,28	B	3,8 8,5	ON...06 SN...16	📦
181089400	125A91245-08-06-040063	8	125	142,1	128,6	138,0	40	90	63	61	3,04	B	3,8 8,5	ON...06 SN...16	📦
181089500	160A91245-10-06-U040063	10	160	177,1	163,6	173,0	40	110	63	61	4,40	C	3,8 8,5	ON...06 SN...16	📦
181089600	200A91245-12-06-U060063	12	200	217,1	203,6	213,0	60	172	63	61	9,12	C	3,8 8,5	ON...06 SN...16	📦
181089700	250A91245-14-06-U060063	14	250	267,1	253,6	263,0	60	172	63	61	11,93	C	3,8 8,5	ON...06 SN...16	📦

📦 Stock item | Produto de stock | Itens de stock

🔗 Available under request (see page A-8) | Disponível sobre consulta (consulte a página A-8) | Disponible bajo consulta (mire pagina A-8)

SPARE PARTS Acessórios | Repuestos

Cutter DC	Insert Screw	Key (Torx)	Order separately		Order separately	
			Key (Torx - Nm)	Torque Value	Screw	DIN 6368 Wrench
A91245 - 63	P0451400	XT20	DT2050	5,0	-	-
A91245 - 80	P0451400	XT20	DT2050	5,0	J0123510	SD6368-12
A91245 -100	P0451400	PT20	DT2050	5,0	J0164110	SD6368-16
A91245 -125	P0451400	PT20	DT2050	5,0	J0204610	SD6368-20
A91245 - 160-250	P0451400	PT20	DT2050	5,0	-	-

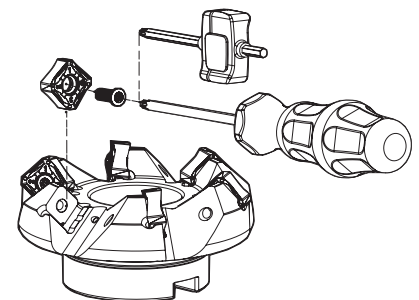

Note: The toolholder is supplied with the XT/PT key. To order the DT key please check the page A-301.
Check the procedures for the clamping screws on the page A-301.

PLUS 91245

ONHX 06 | ONKX 06 | SNHX 16 | SNKX 16

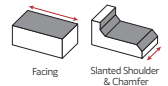

ONH(K)X 06 | SNH(K)X 16 Inserts | Pastilhas | Plaquetas



ONH(K)X-LP



ONH(K)X-MP



ONH(K)X-MK

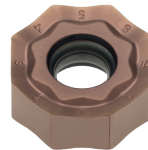

ONHX-LS

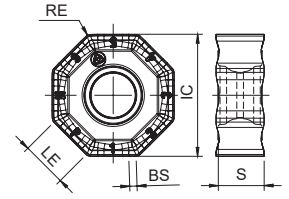

ONH(K)X-LP | MP | MK | LS



ONHX-W
8 Cutting Edges (8R)

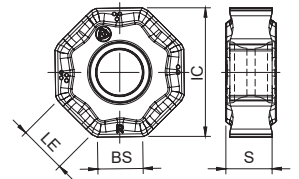

ONHX-W

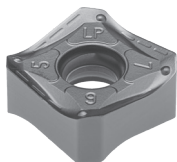

SNHX-LP

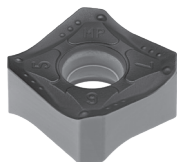

SNH(K)X-MP

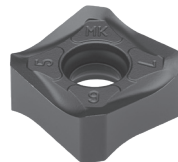

SNH(K)X-MK

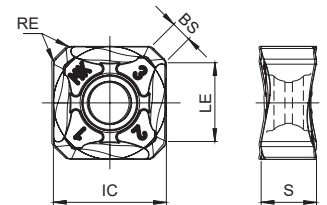

SNH(K)X-MK | LP | MP

(1) Geometry code	(2) Grade code ISO Reference	P						M			K						S			Dimensions Dimensões Dimensiones (mm)							
		CVD		PVD				PVD			CVD			PVD			PVD										
		T9	G4	T1	P3	P4	G6	P3	X9	G6	L5	L6	L9	T9	G4	T1	P3	P4	G6						P3	X9	G6
1111954	ONHX 0606 ANEN-LP			⊗	⊗	⊗	⊗	⊗								⊗	⊗	⊗	⊗	⊗			16,50	6,35	6,20	0,80	1,00
1112696	ONHX 0606 ANEN-LS	○					○	⊗	○				○					○	⊗	○			16,50	6,35	6,20	0,80	1,00
1111955	ONHX 0606 ANEN-MP			⊗			⊗					○			⊗			⊗					16,50	6,35	6,20	0,80	1,00
1111956	ONHX 0606 ANEN-MK											⊗		⊗									16,50	6,35	6,20	0,80	1,00
1112053	ONHX 0606 ANEN-W*		⊗	⊗								⊗		⊗									16,50	6,35	6,20	-	6,00
1112284	ONKX 0606 ANEN-LP	○	⊗	⊗	⊗	⊗	⊗	⊗	⊗		⊗		○	⊗	⊗	⊗	⊗	⊗	⊗	⊗	⊗		16,50	6,35	6,20	0,80	1,00
1112287	ONKX 0606 ANEN-MP	⊗	⊗	⊗			⊗		⊗				⊗	⊗	⊗			⊗					16,50	6,35	6,20	0,80	1,00
1112291	ONKX 0606 ANEN-MK											⊗		⊗									16,50	6,35	6,20	0,80	1,00
1111951	SNHX 1606 ANER-LP			⊗		⊗	⊗		⊗				○		⊗	○	⊗	⊗	○				16,50	6,35	12,50	0,80	2,20
1111952	SNHX 1606 ANER-MP	⊗		⊗			⊗		⊗			○		⊗	⊗			⊗					16,50	6,35	12,50	0,80	2,20
1111953	SNHX 1606 ANER-MK													⊗									16,50	6,35	12,50	0,80	2,20
1112281	SNKX 1606 ANER-MP	⊗	⊗	⊗			⊗		⊗				⊗	⊗	⊗			⊗					16,50	6,35	12,50	0,80	2,20
1112282	SNKX 1606 ANER-MK												⊗	⊗									16,50	6,35	12,50	0,80	2,20

⊗ First choice | Primeira opção | 1ª opción ⊗ Stock item | Produto de stock | Itens de stock ○ Available under request (see page A-9) | Disponível sobre consulta (consulte a página A-9) | Disponible bajo consulta (mire página A-9) Insert order code = (1) Geometry Code + (2) Grade Code

RECOMMENDED CUTTING CONDITIONS Condições de corte recomendadas | Condiciones de corte recomendables

ISO	PSM	Material	HB (Brinell)	Vc (m/min)					
				← Wear Resistance				Toughness →	
				PH5705	PH5320	PHP920	PH7920	PHP930	PHH930
P	1	Unalloyed Steel	125-220	-	-	180-250	180-240	160-230	-
	2	Low-Alloyed Steel	220-280	-	-	160-230	160-220	140-210	-
	3	High-Alloyed Steel	280-380	-	-	140-220	140-210	120-200	-
M	4	SS - Ferritic / Martensitic	200-330	-	-	-	-	-	140-210
	5	SS - Austenitic	200-330	-	-	-	-	-	120-170
	6	SS - Austenitic-ferritic (Duplex)	230-260	-	-	-	-	-	100-150
K	7	Malleable Cast Iron	130-230	160-290	150-280	160-270	160-260	150-250	-
	8	Grey Cast Iron	180-245	170-320	160-320	140-250	140-240	140-230	-
	9	Nodular Cast iron	160-250	140-200	100-190	120-210	120-200	100-200	-
S	11	Heat Resistant Super Alloys	200-320	-	-	-	-	-	30-110

ISO	PSM	Material	HB (Brinell)	Vc (m/min)				Feed fz (mm/t)
				← Wear Resistance		Toughness →		
				PH7930	PH5740	PHS740	PH7740	SNH(K)X/ONH(K)X
P	1	Unalloyed Steel	125-220	160-220	-	140-220	140-200	0,15 (0,25) 0,4
	2	Low-Alloyed Steel	220-280	140-200	-	120-200	130-180	0,15 (0,25) 0,4
	3	High-Alloyed Steel	280-380	120-190	-	100-190	100-170	0,15 (0,25) 0,4
M	4	SS - Ferritic / Martensitic	200-330	140-200	-	-	130-180	0,1 (0,20) 0,3
	5	SS - Austenitic	200-330	120-160	-	-	110-160	0,1 (0,20) 0,3
	6	SS - Austenitic-ferritic (Duplex)	230-260	100-140	-	-	90-150	0,1 (0,20) 0,3
K	7	Malleable Cast Iron	130-230	150-240	160-260	-	140-220	0,15 (0,25) 0,4
	8	Grey Cast Iron	180-245	140-230	140-240	-	120-210	0,14 (0,25) 0,4
	9	Nodular Cast iron	160-250	100-190	120-200	-	100-190	0,14 (0,25) 0,4
S	11	Heat Resistant Super Alloys	200-320	30-100	-	-	30-100	0,1 (0,15) 0,17

(Note 1) Cutting conditions $a_e/D_c=70\%$.

(Note 2) It's possible to occur vibrations in certain cases. Please reduce depth of cut and / or reduce cutting conditions in following cases:

- When using long shank;
- When using long tool overhang with arbor type;
- When application has poor clamping rigidity or when using a low rigidity machine.

GRADES SELECTION GUIDE Guia para selecção de graus | Tabla para selección de calidades

ISO	PSM	Material	HB (Brinell)	Grades									
				← Wear Resistance				Toughness →					
				PH5705	PH5320	PHP920	PH7920	PHP930	PHH930	PH7930	PH5740	PHS740	PH7740
P	1	Unalloyed Steel	125-220	●	●	●	●	●	●	●	●	●	●
	2	Low-Alloyed Steel	220-280			●	●	●	●	●	●	●	●
	3	High-Alloyed Steel	280-380			●	●	●		●	●	●	●
M	4	SS - Ferritic / Martensitic	200-330						●	●			●
	5	SS - Austenitic	200-330						●	●			●
	6	SS - Austenitic-ferritic (Duplex)	230-260						●	●			●
K	7	Malleable Cast Iron	130-230	●	●	●	●	●		●	●		●
	8	Grey Cast Iron	180-245	●	●	●	●	●		●	●		●
	9	Nodular Cast iron	160-250	●	●	●	●	●		●	●		●
S	11	Heat Resistant Super Alloys	200-320						●	●			●

● Good Conditions ● Average Conditions ● Difficult Conditions

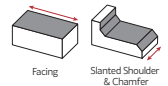

CHIP BREAKER SELECTION GUIDE Guia para aplicações do quebra- aparas | Guía para aplicación del rompevirutas

ISO	PSM	Material	HB (Brinell)	Chip breaker application	
				1st choice	Difficult Operations
P	1	Unalloyed Steel	125-220	LP	MP
	2	Low-Alloyed Steel	220-280	LP	MP
	3	High-Alloyed Steel	280-380	MP	-
M	4	SS - Ferritic / Martensitic	200-330	LS	LP
	5	SS - Austenitic	200-330	LS	LP
	6	SS - Austenitic-ferritic (Duplex)	230-260	LS	LP
K	7	Malleable Cast Iron	130-230	MK	-
	8	Grey Cast Iron	180-245	MK	-
	9	Nodular Cast iron	160-250	MK	LP
S	11	Heat Resistant Super Alloys	200-320	LS	LP

WIPER INSERTS

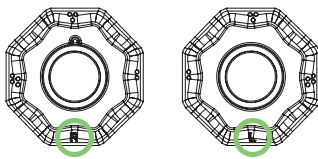

Wiper insert with 4 Right and 4 Left-hand cutting edges. The side work of the insert it's indicated by the letter R (Right) & L (Left).

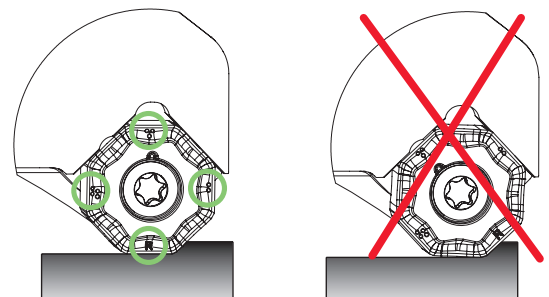

The points and letter (R or L) on the insert indicates the side that should be parallel to the workpiece material.

Recommended Cutting Conditions:

- f_n should be equal to $0,8 \times BS_w$
- Axial depth of cut is 0,5 to 0,8mm.

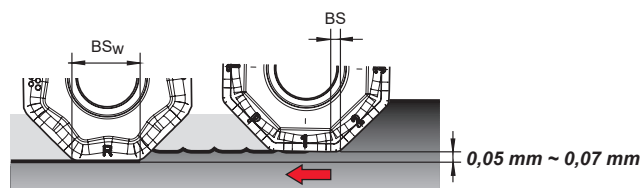

Example:

- The width of the parallel land (BS) of the insert is 1mm.
- To obtain a good surface finishing, the feed per revolution should be a maximum of 80% of 1mm = 0,8mm.
- The wiper insert will have a parallel land (BS_w) with a width of 6,0mm.
- Result: Feed per revolution (f_n) could be increased from 0,8mm to 4,8mm (80% of 6,0mm).

Note:

- Other limitations, such as machine power, must be taken into consideration.
- $f_n \leq 0,8 \times BS_w = f_z \leq 0,8 \times BS_w / Z$

How to use a wiper insert:

- Since wiper is one corner use to standard cutters, please attach the insert with the parallel land down to the workpiece cutting surface.
- The points and the letter (R or L) on the insert indicates the side that should be parallel to the workpiece material.
- The side work of the insert it's indicated by the letter (R - Right & L - Left).

90845 | 90945 | 91245

PLUS

High performance on face milling operations



Check the QrCode for more information



HEADQUARTERS

PALBIT. S.A.

T (+351) 234 540 300 | F (+351) 234 540 301

palbit@palbit.pt | www.palbit.pt

Branch office

PALBIT México, S de RL de CV

T (+52) 5555 454 543 | F (+52) 5552 509 190

info@palbit.com.mx | www.palbit.pt/mx

Branch office

PALBIT Brasil

T (+55) 011 25 343 648

palbit@palbit.com.br | www.palbit.pt/br